



2AS12

**Dual channel 12-bit composite decoder
with 5 line comb filter and frame synchronizer**

A Synapse® product

Synapse



COPYRIGHT ©2008 AXON DIGITAL DESIGN BV

ALL RIGHTS RESERVED

NO PART OF THIS DOCUMENT MAY BE REPRODUCED IN ANY FORM
WITHOUT THE PERMISSION OF AXON DIGITAL DESIGN BV.

Block schematic & I/O panel

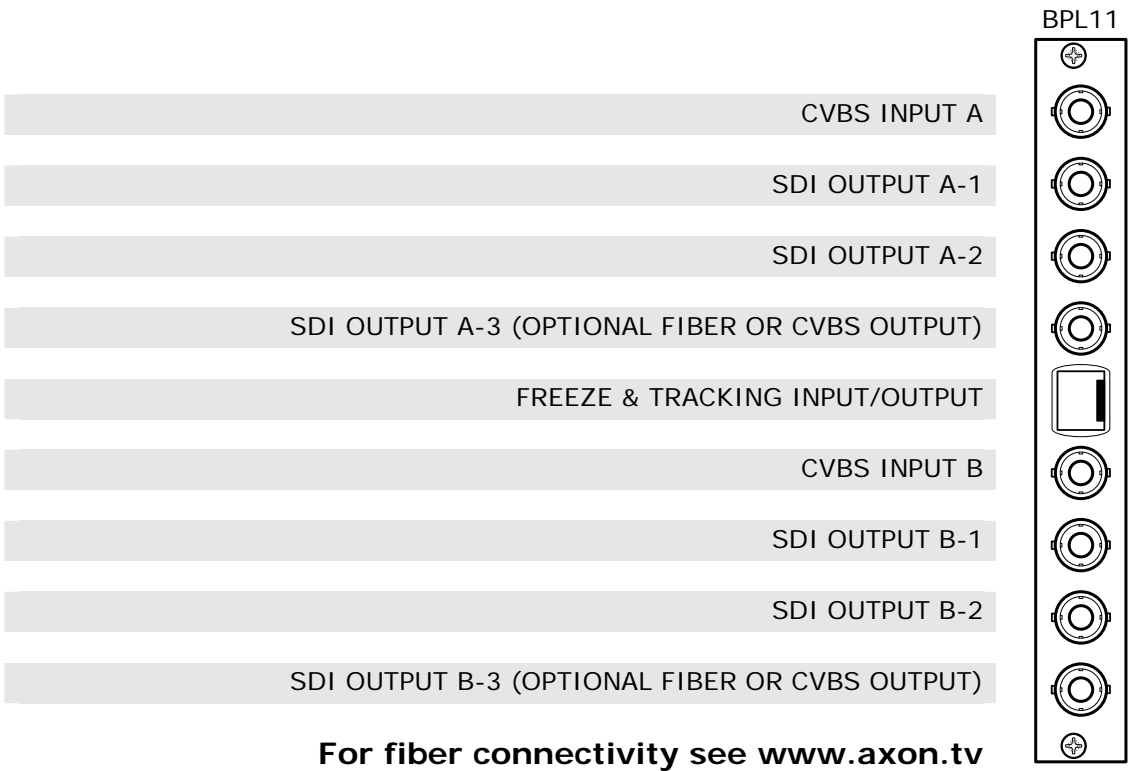
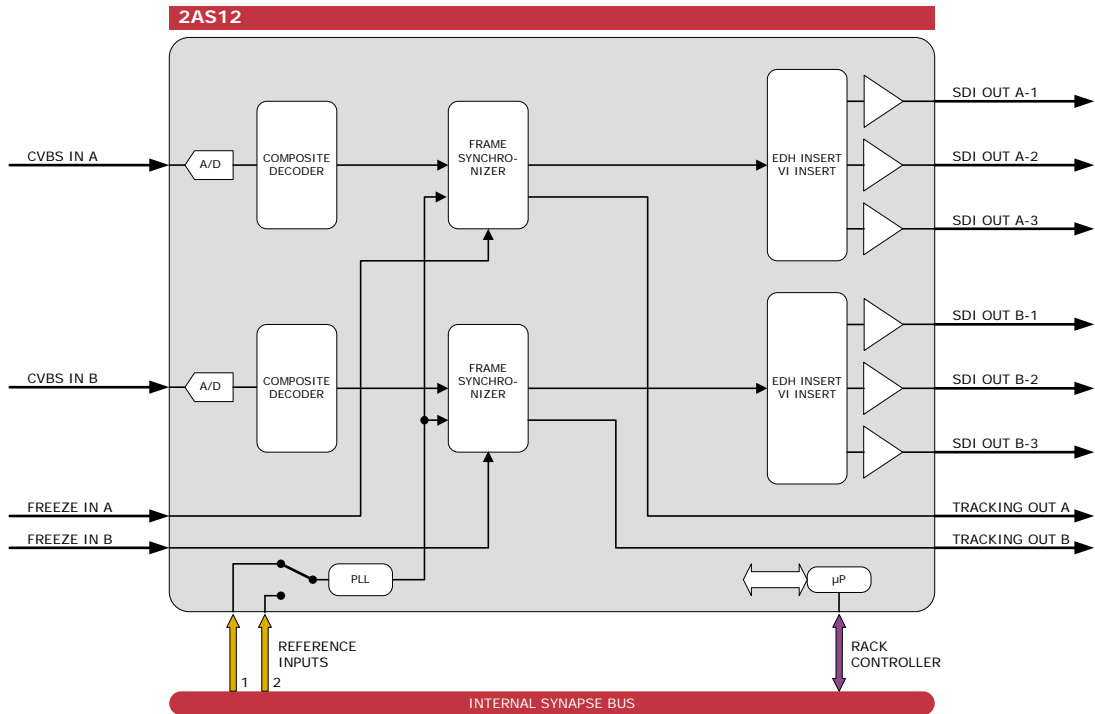

For fiber connectivity see www.axon.tv

Features

The 2AS12 is a broadcast quality dual channel composite decoder with frame synchronizer. The 12-bit high performance digital decoding stages provide superior quality 5-line comb filtering. Because the 2AS12 (TWINS) has 2 fully independent channels, it increases the Synapse decoding density by 100%, allowing 36 individual composite decoder in 4 rack units. When no frame synchronization is required the 2AS11 should be used.

- Dual channel (TWINS)
- 12 bit full broadcast specified decoding
- Compatible with:
 - NTSC-J
 - NTSC-M
 - PAL60
 - NTSC443
 - PAL-BGHID
 - PAL-N
 - PAL-M
 - PAL-M-setup
 - PALcmbN
 - PALcmbN-setup
 - SECAM
 - SECAM-setup
- 3 SDI outputs per channel
- On Input loss display:
 - Black
 - Green
 - Continuous analog input
- Full frame adjustable output phase with respect to reference in sample increments
- Freeze mode
- Audio delay tracking output
- 3 SDI outputs per channel
- 8 channels in 1RU
- 16 channels in 2RU
- 36 channels in 4RU
- EDH insertion
- VI insertion (individual per channel)
- Gain adjustment
- Hue adjustment
- Y shaping filters
- Y peaking adjustment
- Compatible with PAL, NTSC and SECAM
- Full control and status monitoring through the front panel of the SFR04/SFR08/SFR18 frame and the Ethernet port (ACP)
- Optional 2 fiber outputs (replacing 2 SDI outputs) on I/O panel
- Optional 2 CVBS outputs (replacing 2 SDI outputs) on I/O panel

Applications

- The 2AS12 is ideal for converting non sync CVBS sources into SDI
- High density multi channel decoding

Ordering information

Module:

- **2AS12:** Dual 1-bit composite decoder with 5 line comb filter and frame synchronizer

Standard I/O:

- **BPL11_2AS12:** I/O panel for 2AS12

Fiber outputs:

- **BPL11T2_FC/PC_2AS12:** I/O panel for 2AS12 with 2 fiber transmitters on FC/PC
- **BPL11T2_SC_2AS12:** I/O panel for 2AS12 with 2 fiber transmitters on SC

CVBS outputs:

- **BPL11C2_2AS12:** I/O panel for 2AS12 with 2 CVBS outputs

Specifications

Video Input

Standard	PAL (ITU624-4), NTSC (SMPTE 170M)
Number of Inputs	1
Impedance	75 Ohms
Return Loss	> 35dB up to 10MHz
Frequency Response	< ±0.25dB (100KHz to 4.2MHz)
Differential Gain	< ±0.5% typical
Differential Phase	< ±0.2° typical
Noise Floor	< -57dB RMS (black video, 15KHz to 5MHz)
C/L Gain	< ±0.5%
C/L Delay	< ±9 ns
Minimum Delay	3 lines
Maximum Delay	1 frame

Reference Video Input

Standard	PAL (ITU624-4), NTSC (SMPTE 170M)
Number of Inputs	2 on SFR18, 2 on SFR08, 1 on SFR04
Connector	BNC
Signal Level	1V nominal
Impedance	75 Ohms
Return Loss	> 25dB to 10MHz

Serial Video Output

Standard	SMPTE 259M 525/59.95 or 625/50
Number of Outputs	2
Connector	BNC
Signal Level	800mV nominal
DC Offset	0V ±0.5V
Rise/Fall Time	900ps nominal
Overshoot	< 10% of amplitude
Return Loss	> 15dB to 270MHz
Jitter	< 0.1UI

Miscellaneous

Weight	Approx. 250g
Operating Temperature	0 °C to +50 °C
Dimensions	137 x 296 x 20 mm (HxWxD)

Electrical

Voltage	+24V to +30V
Power	4 Watts